

IMPACT LED SIGNS

- INSTALLATION GUIDE -

Table of Contents

Page 1	-- Table of Contents
Page 2	-- Ventilation
Page 3	-- Cabinet Details
Page 4	-- Mounting
Page 5	-- Electrical
Page 6	-- Grounding
Page 7	-- Double-Sided EMCs
Page 8	-- Modules
Page 9	-- Ambient Light & Temp Sensors
Page 10	-- Network Configuration
Pages 11-12	-- Connectivity
Page 13	-- Maintenance Guidelines
Page 14	-- Notes

Ventilation

Ventilation Requirements

Electronic Message Centers (EMCs) require ventilation. As illustrated, Impact EMCs use fans located inside the top of the cabinet to draw fresh/cool air in through vents at the bottom of the cabinet's rear side and out of vents located at the top. Improper ventilation will result in the EMC overheating. Impact's EMCs will shut themselves off when they overheat & will restart after cooling. However, overheating will cause damage, thus ventilation should be carefully considered.

When installing an IMPACT EMC allow a minimum of 24 square inches of total air intake and 24 square inches of exhaust per foot of cabinet length. Ideal ventilation: 2" gap at top and bottom.

Insufficient ventilation will result in the voiding of the warranty.

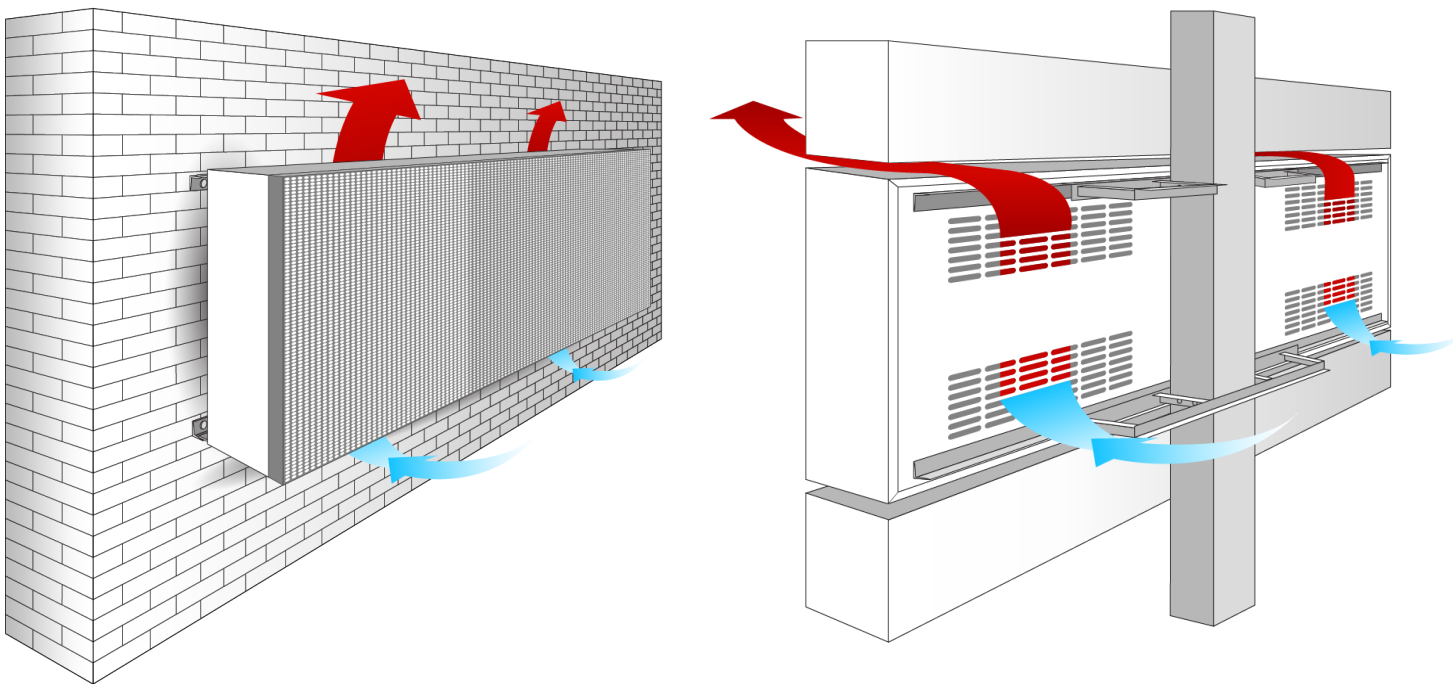

Alternative Acceptable Ventilation Options:

If no ventilation is available at top: Provide a 2" gap on each side and bottom. If perforated panels are used the material should have no less than 40% open area. A horizontal air baffle should be used to discourage exhaust from being recirculated in the cabinet.

Cabinet Details

Sign Cabinet

Impact EMCs are built to last. Both the lightweight aluminum cabinet and steel mounting angle are powder coated for a durable finish. Lifting plates are located at the top of the display and can be removed as their threaded cavities do not pass through to the inside of the cabinet - Impact recommends filling the cavity with silicone or utilizing the bolt after removing the lifting plate to prevent water from freezing and breaking the seal.

Electronic Message Center Cabinets

Impact Electronic Message Centers come built into an **Aluminum black powder coated cabinet**. No additional weatherproofing cabinetry is required.

Steel mounting angles near the top and bottom of the back of the aluminum cabinet allow for an easy installation. These mounting angles are punched with mounting slots further simplifying the installation by eliminating the need to drill holes.

The **removable lifting plates** are designed to make lifting the cabinet simple and safe.

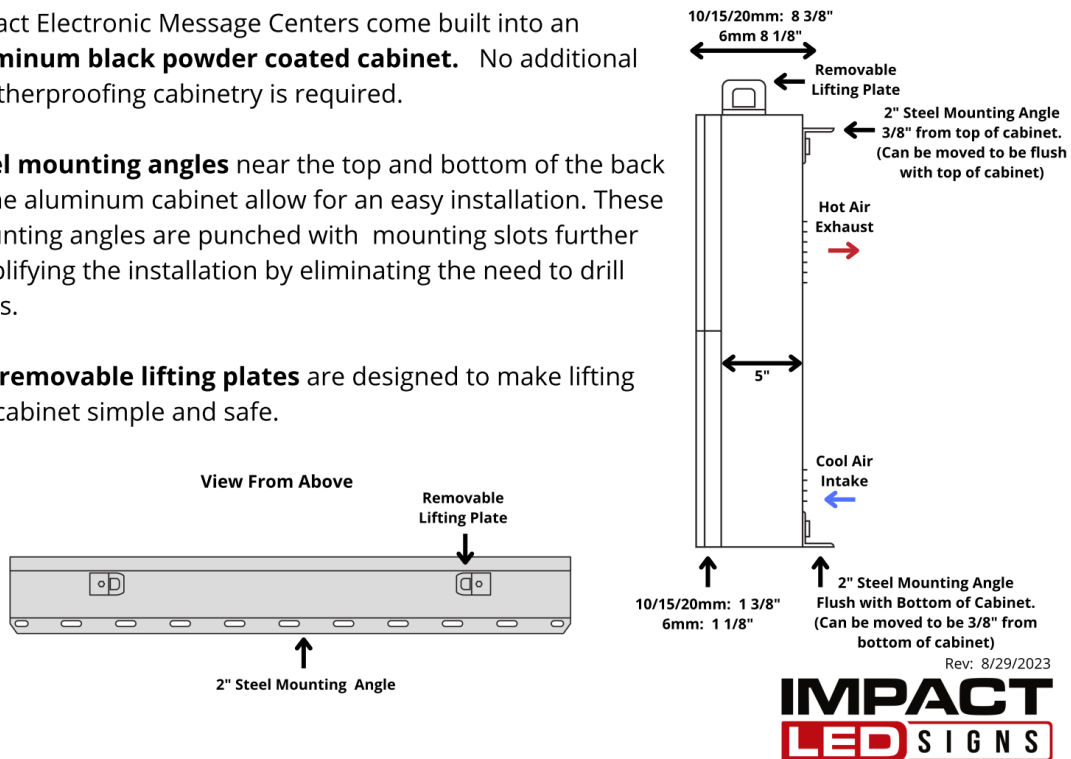

A 2" x .125" thick steel mounting angle runs the length of the top and bottom of each Impact single cabinet enclosure EMC. This design provides tremendous flexibility in mounting.

(Angle may vary based on product line selected. Always refer to the production drawing for measurements.)

Mounting

General Mounting Guidelines

This information is for general reference. It does not replace professionally engineered drawings. Please contact the Impact LED Project Management Team with any specific questions. **Project Management can be reached at (800) 398-0576 x 5**

Steel mounting angles are provided on the back of each LED sign cabinet. Fasteners, support columns, brackets and electrical wiring conduit/accessories are not provided unless specifically included as a line item from Impact LED.

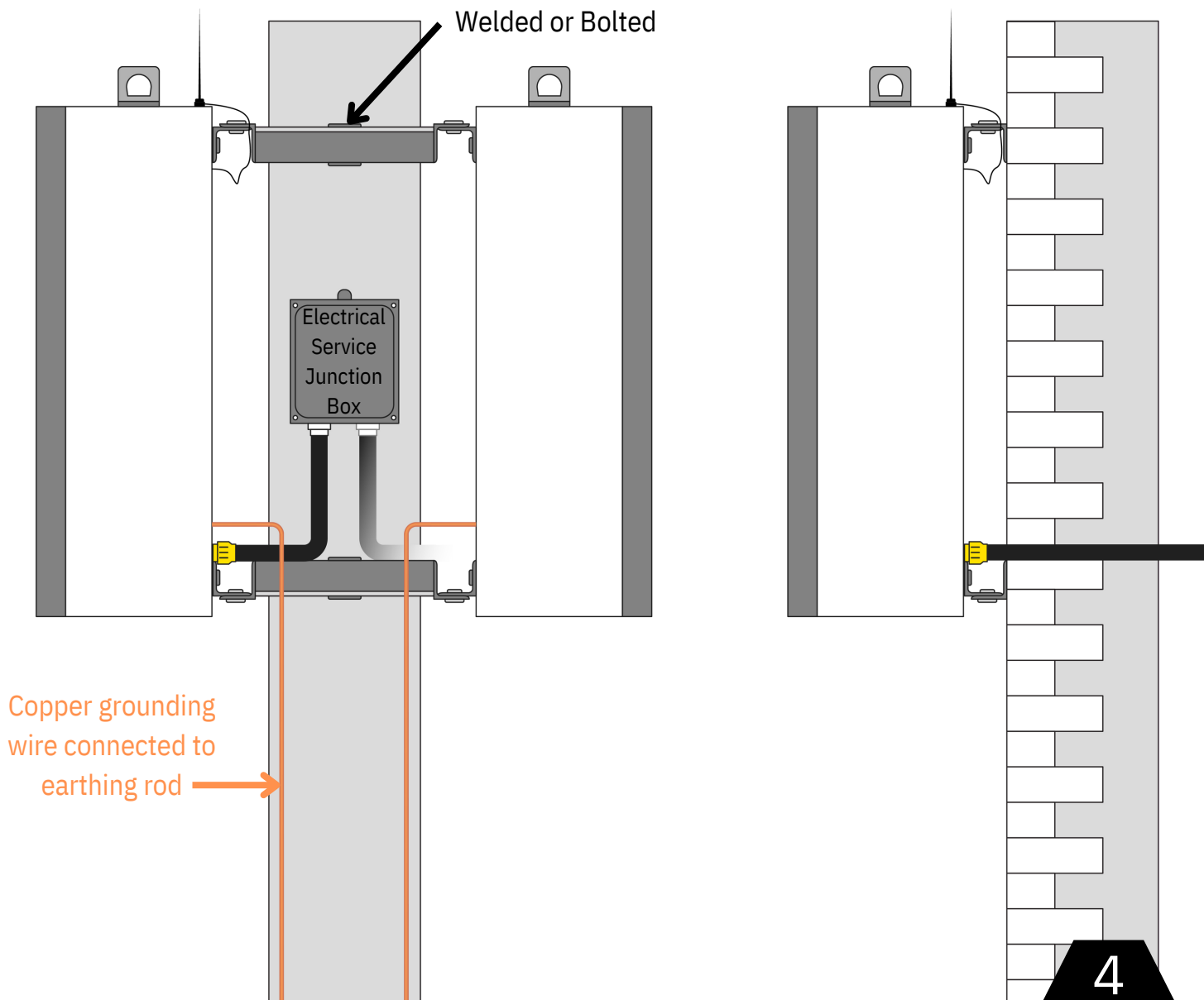

Electrical

Electrical Information

Consult your original quote, the sign's MET UL48 Standard Label and/or Impact LED provided shop drawing for electrical load requirements.

Best Practices for Power:

- Install all EMCs per National Electric Code.
- Always check the MET UL48 Standard label on the back of the primary unit and shop drawings to confirm voltage.
- Always follow lock-out/tag-out procedures to ensure safety when working on, installing or connecting to electrical lines.
- Each EMC should be on a dedicated circuit without a photocell or timer.
- Each EMC should have an in-earth copper ground rod 3/8" diameter and at least 6' long.
 - **Failure to provide proper grounding will result in the voiding of the warranty.**
- Always verify primary power voltage and continuity before connecting power to the EMC.
- Connection to the EMC should be a dedicated circuit run to a watertight junction box or breaker panel and then a secondary whip (provided with the sign) connecting the junction point to the back of the sign cabinet at the Power Input location.

****If you have any questions, please contact the Project Management Team at Impact LED Signs by calling 1-800-398-0576 x 5***

Grounding

Display Grounding Guidelines

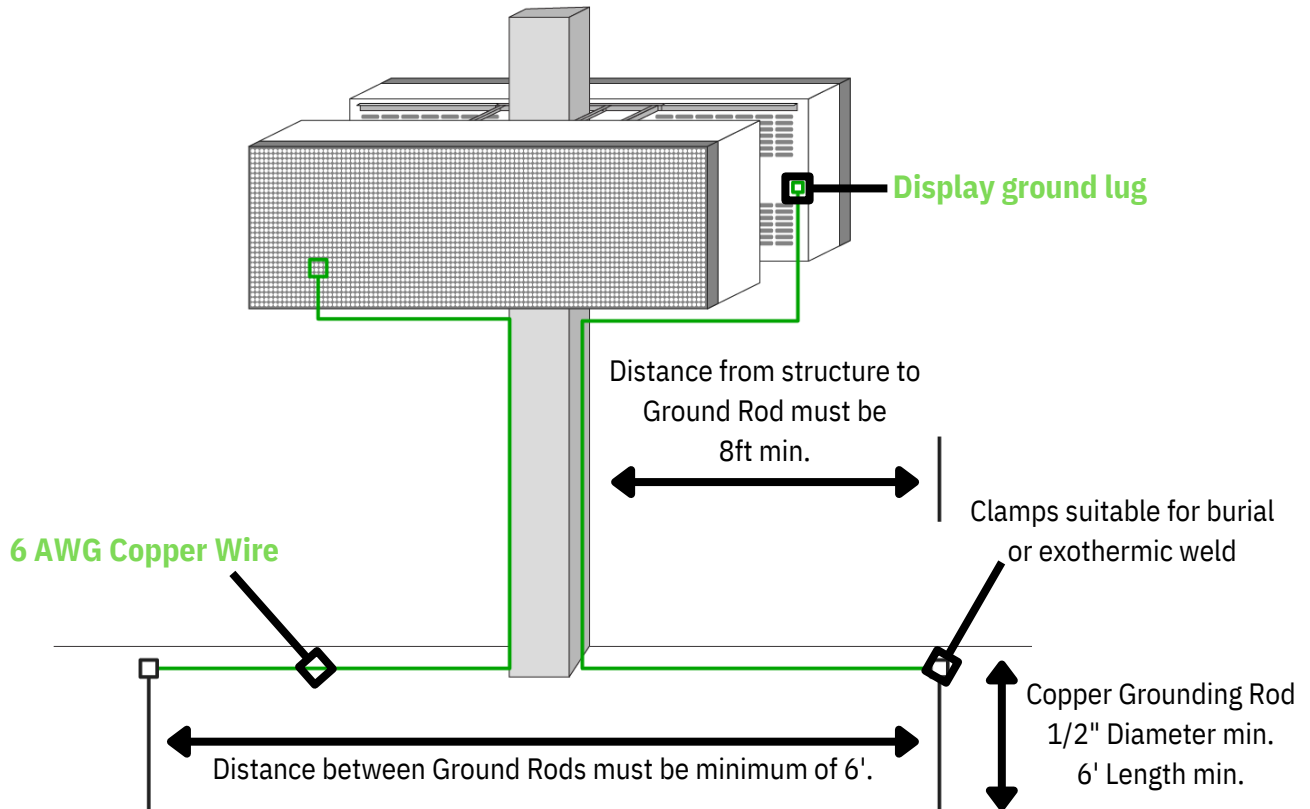

- Grounding copper wire (conductor) must run from the grounding lug of the display cabinet direct to the grounding rod.
- At no point in time can the display structure (support structure, pole) be used as a means of grounding the display cabinet. Although a steel structure is conductive, a copper rod maintains to be a superior conductor throughout the life of the sign. Also, NEC Sec. 250-54 requires the resistance to ground of a single-made electrode to be 25 ohms or less.
- For signs built in a modular configuration (multiple cabinets used to create 1 display face) the grounding wire may only be connected to the grounding lug of one cabinet of the display face.
- It is recommended that each cabinet or display face have an independent grounding rod.
- It is recommended that the grounding wire be connected to the grounding rod by exothermic weld.
- Grounding rod must be completely buried at a minimum of 6ft (length of the rod).
- Grounding wire must be one continuous length without a splice or joint (NEC250.64 C).
- Distance of 8ft is recommended between display structure and grounding rod or a measured grounding resistance of 10 Ohms or less.
- Distance between grounding rods must be a minimum of 6ft from one to another.

Double-Sided EMCs

Primary/Secondary Sides of an EMC

The information on this page is only applicable to Two-Sided Displays built in a Primary/Secondary configuration.

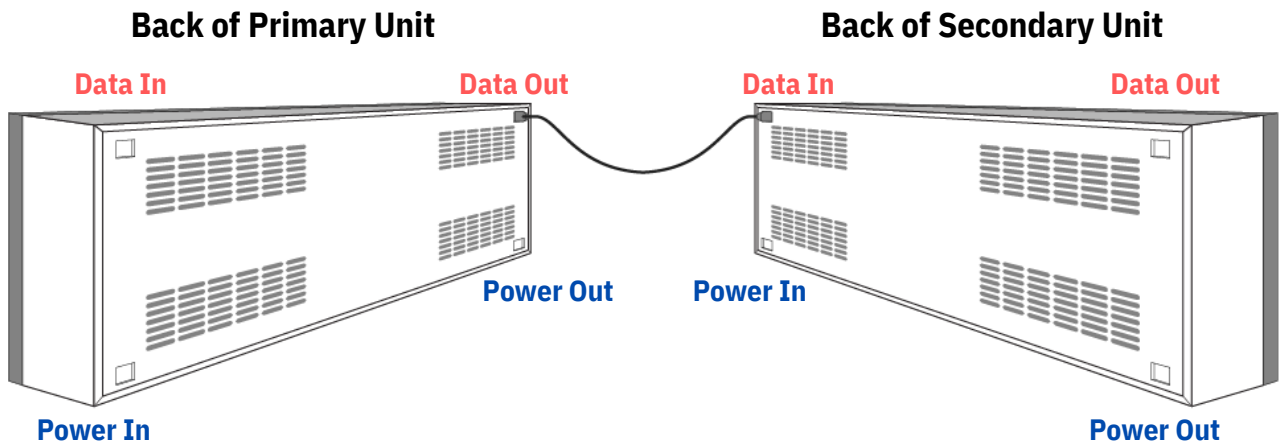

Locate the quick access data connection ports on the Primary unit and Secondary unit. Firmly seat the cable to ensure a solid connection. Gather and zip tie any loose cable. The **Input Data Port** is located on the left side when looking at the back of the unit.

The **Output Data Port** is located on the right side when looking at the back side of the Primary unit.

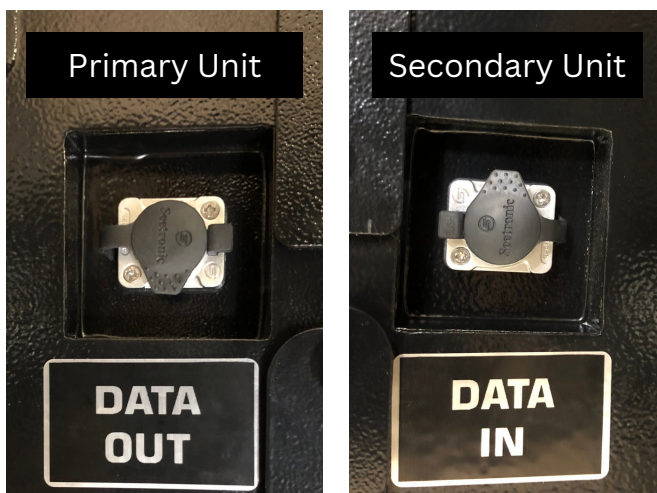

Modules

Removing Modules

TURN POWER TO THE EMC OFF!

Each LED module features a hole in each corner, approximately 1" from each edge. This hole on the 10, 15, and 20mm modules accepts a 3mm hex head wrench, and the 6mm modules accept a 2mm hex wrench. Insert the wrench and once seated gently turn counter clockwise to disengage the module locking mechanism. A “click” sound will indicate the lock is fully disengaged. All four locks will need to be disengaged to remove the module.

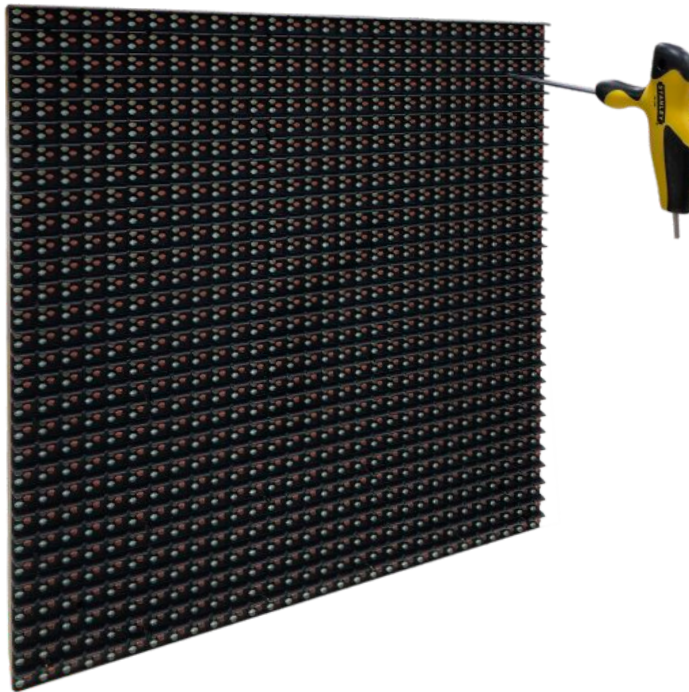

As you remove the module from the EMC, disconnect the power and data cables.

NEVER LET MODULES HANG FROM POWER/DATA CONNECTIONS

A SAFETY CABLE IS INSTALLED TO PREVENT THE MODULE FROM FALLING. ALWAYS REINSTALL SAFETY CABLE WHEN REPLACING MODULE.

Ambient Light & Temp

Ambient Light Sensor

The ambient light sensor picks up the surrounding light level to automatically dim and brighten the display.

The ambient light sensor features removable, threaded washers which can be used to secure the sensor to a bracket or panel. Be sure to coil, zip tie and secure any excess cable.

The brightness sensor should be facing the direction that will allow for the most light to access the sensor as early in the day as possible. Typically that is either on the Southern exposed face or on the top of the sign. Try not to put the brightness sensor in the shade or behind any objects.



Temperature Sensor

Most Impact Electronic Message Centers do NOT come with a temperature sensor. This is because the Impact Cloud+ software (compatible with all connectivity methods) automatically retrieves weather and temperature information via an online weather application.

In the event your sign is running Impact PC Pro (Impact's PC based software), the temperature function is not a standard feature. If the temperature function is required please contact our technical support for assistance.

Technical Support can be reached at (800) 398-0576 x 3

Network Configuration

Network Configuration Requirements

Any Electronic Message Center communicating with our Cellular Modem option is considered to be "Plug and Play" and does not require additional configurations to be made. Electronic Message Centers communicating with our Wireless Network Bridge option leaves the factory configured for DHCP by default. To ensure a swift and easy installation, the local network may need to be prepped for our cloud controllers.

The fall-back addresses are:

Sign Side Radio: 192.168.0.219

Building Side Radio: 192.168.0.218

General Connectivity Configuration

On most networks, minimal configuration is needed and the signs are plug and play. Network Traffic for the EMC needs to be opened to our Main Server Address:

Access.[Impactledsigns.com](https://www.impactledsigns.com)

For Cloud signs to communicate properly,

Ports:

HTTPS 443/TCP

websocket 8443/TCP

NTP 123/UDP

- **Network traffic must be open to Amazon S3 bucket: weather.cloudled.com**
- **Network traffic access needs to be granted through all firewalls and all filtering systems.**
- **This is a basic outline of the network configuration requirements, additional changes may be required.**

For technical questions please reach out to tech@impactledsigns.com or 1-800-398-0576 x 3

Federal Communications Commission Interference Statement

This device complies with part 15 of the FCC Rules. Operation is subject to the following two conditions: (1) This device may not cause harmful interference, and (2) this device must accept any interference received, including interference that may cause undesired operation. This equipment has been tested and found to comply with the limits for a Class B digital device, pursuant to part 15 of the FCC Rules. These limits are designed to provide reasonable protection against harmful interference in a residential installation. This equipment generates, uses and can radiate radio frequency energy and, if not installed and used in accordance with the instructions, may cause harmful interference to radio communications. However, there is no guarantee that interference will not occur in a particular installation. If this equipment does cause harmful interference to radio or television reception, which can be determined by turning the equipment off and on, the user is encouraged to try to correct the interference by one or more of the following measures:

- Reorient or relocate the receiving antenna.
- Increase the separation between the equipment and receiver.
- Connect the equipment into an outlet on a circuit different from that to which the receiver is connected.
- Consult the dealer or an experienced radio/TV technician for help.

FCC Caution: Any changes or modifications not expressly approved by the party responsible for compliance could void the user's authority to operate this equipment.

Connectivity

Connectivity Methods

Cellular

Impact LED utilizes the Verizon network infrastructure. Connectivity can vary from location to location depending on tower coverage and ambient conditions. Even though the modem is mounted and powered inside the LED sign cabinet, Impact LED provides external antennas with each modem and requires that they be external to the sign, as high as possible above the LED sign. It is the Dealer's responsibility to securely mount and document the location of the antenna as well as test connectivity prior to leaving the installation.

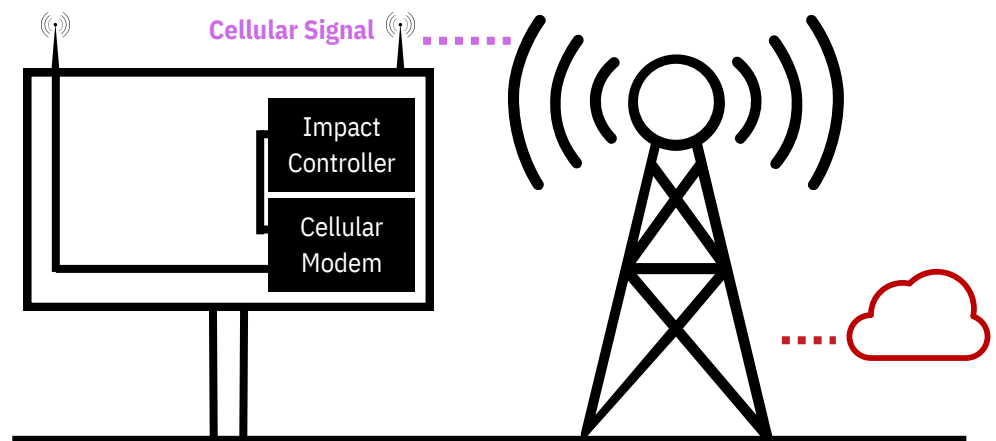

Wireless Network Bridge

Wi-Fi bridge kits are also a viable solution for many applications. This WPA encrypted connection is a point-to-point link between two transceivers, which have been pre-paired to communicate with each other. With a clear line of sight, a Wi-Fi bridge kit can provide 100mbps transmissions over distances in excess of 1 mile. Both transceivers should be facing towards each other with as few (if any) obstructions between them as possible. The "Receiving" transceiver should always be mounted on the outside of the sign. The "Sending" transceiver should be mounted external to the building.

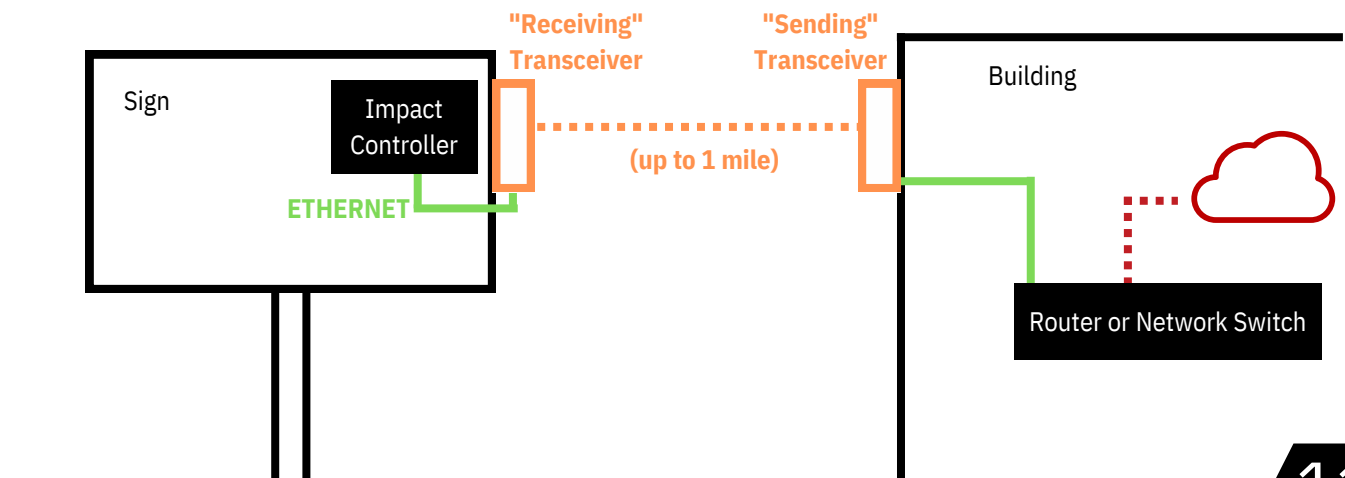

Connectivity

Connectivity Methods

Direct Ethernet

Impact LED signs accept a standard RJ45 ethernet connection. This is also referred to as a Cat5e/Cat6e cable, network cable, or LAN cable. The cable would be connected to the router or network switch inside the building and the back of the primary unit of the Impact LED Sign. Any cable run over 300' should be boosted by a network switch.

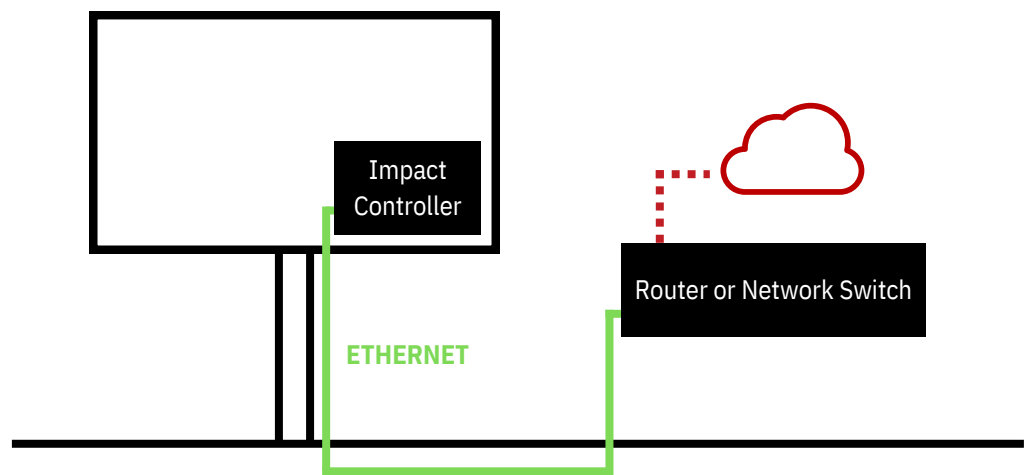

Fiber

Fiber can be a great option for locations with no cellular service who require connectivity over a significant distance. Confirm the fiber specifications with your Impact LED Project Manager prior to installation. Impact LED provides SC fiber media converters which are wide temperature/industrial grade.

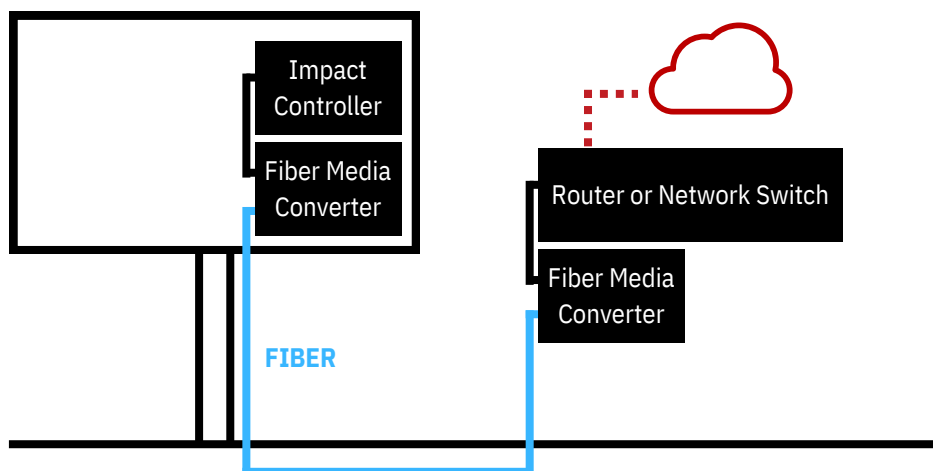

Maintenance Guidelines

The outer cabinet should be washed only with water. A garden hose without a nozzle and a lint-free cloth should be sufficient and gentle enough to wash the EMC – water should be applied on the top of the sign and allow it to flow down like rain. Never spray up or sideways at the LEDs. No pressurized water should be used at any time.

No chemical solutions should be used on the sign, the pixels, rear covers, or doors.

No type of abrasive cleaner should be used to clean any part of the display. This includes sponges with light or harsh abrasives, or brushes. Using these types of cleaners could slowly remove or damage the paint on the cabinet over time.

If touch-ups on the metal surfaces of the cabinet are necessary, use Black, Semi-Gloss exterior paint. Wipe down with mineral spirits or denatured alcohol before painting.

The internal hardware of the display should be cleaned with compressed air at the end of every summer to remove any build-up of dust and dirt. **The AC power to the display must be turned OFF before you begin.** This is for your safety and to prevent damage to any components.

Ventilation System: The ventilation system should be checked yearly to ensure that the display venting system is operating correctly before the summer season begins. The exhaust fans should be checked bi-annually if the display is installed in a dusty, hot environment or areas where insects are problematic.

- Exhaust Fans: Exhaust fans should be cleaned before each summer season begins or after any large dusty days/construction.
- Turn the AC power OFF to the display.
- Use a thin screwdriver or q-tip and insert it between the fan blades to prevent the fan from moving or spinning.
- Use a small compressor or industrial portable vacuum to blow out dust.
- Perform this to all exhaust fans in the display. Do not do this while AC power is ON, or allow the fans to spin while you clean them.
- Failure to do so may cause the fans to over spin and damage the fans.
- Dust Build Up: At times, it may be necessary to vacuum the inside of the display to remove any dirt/dust that may interfere with airflow.

Loose Hardware: Verify that screws or bolts have not come loose on vital components such as power supplies or receiving cards.

Cabinet: It is extremely important to clean out all dust or dirt in the display near the electronic components. Failure to do so will result in dust/dirt being pulled back into the power supplies, causing the fans to seize. A 4" paint brush is recommended to dislodge any standing dirt/dust and a vacuum to remove the dirt/dust.

Notes



IMPACT

LED SIGNS

This is a printout of our Installation guide revised 1/19/2023.
For the most up-to-date version, please check <https://impactledsigns.com/>